

IoT based Patient Monitoring System

TEJ PRAKASH SAHU¹, DR. VINAY KUMAR JAIN²

¹(ME, Student) Department of Electronics & Telecommunication Engineering, Shri Shankaracharya Group of Institutions SSTC Junwani Bhilai (CG)

²Asso. Professor & Head of Department of Electronics and Telecommunication Shri Shankaracharya Group of Institutions SSTC Junwani Bhilai (CG)

ABSTRACT - IoT (Internet of Things) is utilized as a part of a great deal of uses. A portion of the uses of Internet of Things are savvy stopping, shrewd home, brilliant city, keen condition, mechanical spots, horticulture fields and wellbeing observing procedure. One such application is in medicinal services to screen the patient wellbeing status by means of Internet of Things makes therapeutic gear more effective by permitting ongoing checking of patient wellbeing, in which sensor get information of patient's and decreases the human blunder. Proposed IoT based design useful for COVID-19 disease .It Helps doctor to monitor the patient and also surrounding condition of patient. This will increase the ability to address a problem before a patient requires acute care. We have ability to remotely monitor vital signs of a patient in real-time .Our system is simple, low-cost and compact. This research outlines the design and development of a cost effective and reliable wireless sensing device which is based on NODE MCU microcontroller for collecting real-time health vital signs such as human body temperature and heart beat rate. It helps in online diagnosis and manage health more efficiently, without the going out of the home.

Keywords: IoT ; Heart beat Sensor, Node MCU ,Temperature Sensor.

I. INTRODUCTION

Internet of Things (IoT) or Web of things is the rapidly growing and updated technology that connects smart objects with one another over the internet. In the health care industry, there are different machines and equipment involved to track a patient's health parameters and as such can be improved .Technology is improving, and so the healthcare applications. Health care is a critical science to deal with because it involves a human life which cannot be risked for lack of advanced healthcare devices [2]. The main drawback in the current patient monitoring system is the requirement of the physical presence of the doctor in the vicinity of the patient, which is not possible at all times. Hence it becomes necessary to develop a system which does not demand the doctor's presence for patient monitoring.[16] In the recent years use of wireless technology is increasing for the need of upholding various sectors .In these recent years IoT groped the most of industrial area specially automation and control. [10]Biomedical is one of recent trends to provide better health care. Not only in hospitals but also the personal health care facilities are opened by the IoT technology. So having a smart system, various parameters are observed that consume power, cost and increase efficiency .In accordance with this smart system, this paper is reviewed.[8]

It initially included firmware which runs on the ESP8266 Wi-Fi SoC. The firmware uses the Lua scripting language. The firmware is based on the eLua project, and built on the Espressif Non-OS SDK for ESP8266. It is good and intelligent technique which reduces human effort and easy access to physical devices. This technique also has independent control feature by which any device can control without any

human interaction.[19][17] One of the key learning stages for IoT be the NodeMCU. NodeMCU is a low-cost open source IoT platform.

II. LITERATURE REVIEW

Abhilasha Ingole et. al [1] have proposed a paper which describes “Implementation of Healthcare monitoring System using Raspberry Pi”. This model is implemented to check the temperature of body and heartbeat of patients at runtime. It is focused on collecting the physical parameter and then that information is made available for multiple users.They have used Raspberry Pi B+ model. It is interacted with different parameters measuring unit. In this system,basic health parameter are considered and monitored.

Augustus E. Ibhaze et. al [2] have designed a system called “E-health Monitoring System for the Aged”. This system checks the heartbeat as well as temperature of patients simultaneously with the pulse sensors and the temperature sensors by populating a centralized database with its reading of defined intervals. By using Arduino microcontroller sensors attached to the figure of the patient for measuring temperature and heart rate. Also it is designed to recognize the location of the patients.

Prosanta Gope et al.[3] proposed a model,” BSN Care: A Secure IoT Based Modern Health Care System Using Body Sensor Network”. This system represents a body sensors technology. It consist of wearable body sensors like EMG(Electromyography),ECG(Electrocardiogram), blood pressure etc. It uses wireless communication using 3G/GPRS/CDMA.

Kaleem Ullah, et. al.[4] This presents the system called as ‘k-Healthcare’. It uses four layers, sensor layer, network layer, internet layer and service layer. They have used sensors like smart phone sensors, RTX-4100, Arduino, Raspberry Pi, pulse oximetry. For data storage management the system used cloud storage. The proposed system support different protocols and like HTTP, HTTPS, RESTful and Javascript web services.

Mohanraj , et al. [5] reported the performance of sensors on integrated to LabVIEW through Arduino to provide a GUI based environment and monitoring Parameters that are displayed on the LabVIEW front panel. This LabVIEW front panel is published over the web server with both access and control permissions with a unique IP address[3].The doctor can make use of this IP address to access the monitoring system. The results of the LabVIEW are synergetic activities gathered in various fields of knowledge like telecommunications, informatics and electronics.

Lakmini P. Malasinghe, et al. [6] had studied remote healthcare and monitoring in both with-contact and contact less methods. It mainly includes technology varies from sensors attached to body to ambient sensors attached to the environment and new breakthroughs show contactless monitoring which requires only the patient to be present within a few meters from the sensor with wireless communication and also data mining kept in new premises in the field of personal health care.

Mohammad Shahidul Islam, et al. [7] actualize supporting sensors integrated with IoT healthcare which can effectively analyze and gather the patients’ physical health data that has made the IoT based healthcare ubiquitously acceptable. The communication with the hyper-terminal program using LoRa has been implemented and an IoT based healthcare system is being developed in Signals platform with the expected results getting from the sensors.

K. M. Monica, et al.[8] talked about screens patient's body temperature, breathe rate, heart beat and body improvement . These sensors are associated with Arduino UNO and Linux server . In the wake of

gathering information from sensors, the information be up physically . For observing reason application and site page for checking wellbeing.

Ismail I, et al.[9] in their study found the design of a software system, written in C-Language (C) which is capable of monitoring patient's temperature, pulse-heart beat rate, TP-HBR is capable of receiving the data from the remote device and storing the data to a central database. With this technologies and intelligent systems, patients will be able to monitor their own vital health signs from home and communicate the results to their health providers wirelessly. This will increase the ability to address a problem before a patient requires acute care.

III. COMPARISON AND DISCUSSION

By studying the reference papers, we found that authors have proposed various systems and designs which are based on IoT for patient monitoring. The researcher provide design based on Raspberry Pi [1] arduino[2] , GSM, GPRS, GPS[3], RTX-4100, Arduino, Raspberry Pi, pulse oximetry sensor [4], arduino and GUI [5], BLE, ZigBee, Wi-Fi, SigFox and LoRa [7], Arduino UNO and Linux server [8] and software based on C language with various sensor[9]. All the research paper are based on patient body monitoring using various microcontroller and sensor. All are using IoT technology.

In the our proposed method of patient monitoring system monitors patient's health parameters using different sensors with NodeMCU which having inbuilt wifi and its performance is better than arduino. Whole system is based on latest IoT technology.[10] Our proposed design not only providing patient information but also it providing ambience status temperature, humidity and graphical analysis.

The sensors attached to the body of the patient which are temperature and heartbeat sensor and also for room condition we have temperature and humidity sensor.[18] The sensors used for checking blood pressure, for pulse rate and temperature sensor of the patient. NodeMCU collect information from sensor and process the information and inbuilt Wi-Fi used to connect with internet. [15] A mobile application design for the doctor to check health status of the patient. Data is updated in every 60 seconds.

IV. PROPOSED SYSTEM

Main purpose of IoT based system to help healthcare system in case of emergencies. The system self monitor [12][13] and able to inform critical situations of patients to the doctors and it also

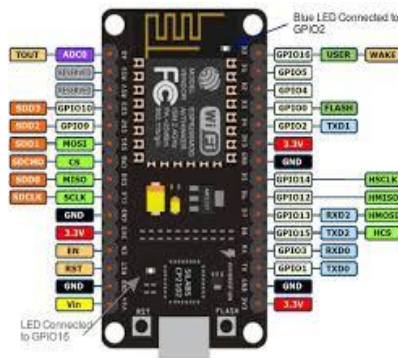

Fig.1 Node MCU

help in monitoring room ambience form remote location. Sensors signals are send to Node MCU via connections.[20] Here patients body temperature , humidity and pulse rate is measured using respective

sensors and it can be monitored in the screen of mobile app using Node MCU connected to a cloud database system as well as monitored anywhere in the world using internet source. The name "Node MCU" combines "node" and "MCU" (micro-controller unit).

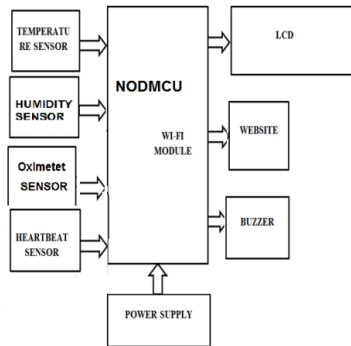

Fig.2 Block diagram

The doctor will be automatically intimated if any of parameter will cross the threshold value which may produce health problem through mobile application. [14]Block diagram of proposed system shown below in fig.2

V. RESULT

By the study of research paper we know that all are using microcontroller or arduino board and for IoT implementation we have to use separate Wi-Fi module. In our method we are using NodeMCU , which is an open-source firmware and development kit and it is very suitable for IoT. Main advantage of NodeMCU microcontroller is that it combines the features of WIFI and Microcontroller. Oximeter, temperature and humidity sensors which are connected to NodMCU. Then this data is uploaded using Wi-fi module ESP8266 to the IOT .Using blink app we can monitor patient and ambience. Real time Result is as shown in Table 1and result on blink app shown in fig 3 below.

Table 1 Results on blink app

Parameters	Value
Temprature	32 C
Humidity	70
Pulse rate	87 pulse

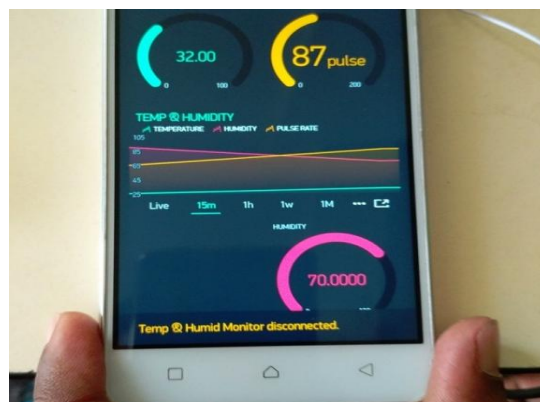

Fig.3 Sensor value displayed in cell using app.

We use Blynk app for mobile. Blynk was designed for the Internet of Things. It can control hardware remotely, it can display sensor data, it can store data, visualize it and do many other cool things.

Blynk App: – It allows you to create amazing interfaces for your projects using various widgets which are provided.

Blynk Server: – It is responsible for all the communications between the smartphone and hardware. You can use the Blynk Cloud or run your private Blynk server locally. It's opensource, could easily handle thousands of devices and can even be launched on a Raspberry Pi.

Blynk Libraries: – It enables communication, for all the popular hardware platforms, with the server and process all the incoming and outgoing commands .blynk structure shown in fig 4 below

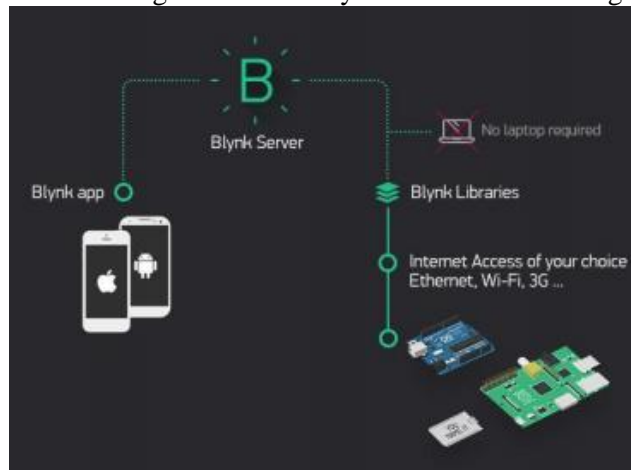

Fig 4 Blynk structure Working with Phone

VI. CONCLUSION

IoT based design is helpful for an infected patient of COVID-19 and provides better treatment rapidly. It is useful for patient, physician, surgeon and hospital management system. For future enhancement we can add ECG measurement as well as voice support system with IoT. Role of Internet of Things technology is very important in the field of healthcare sector.[11] IoT based Proposed design can able to provide better accuracy and status in real time. System is portable so that it can be tie up with patient and parameter can be monitor on mobile application through internet connectivity.

REFERENCES

- [1].Abhilasha Ingole, Shrikant Ambatkar, Sandeep Kakde,“Implementation of Health-care Monitoring System using Raspberry Pi”, IEEE ICCSP 2015 conference., 978-1-4799-8081-9/15/\$31.00 © 2015 IEEE.
- [2]. Augustus E. Ibhaze, MNSE, Francis E. Idachaba, “Health Monitoring System for the Aged” 2016 IEEE, International Conference on Emerging Technologies and Innovative Business Practices for the Transformation of Societies (EmergiTech), 978-1- 5090-0706-6/16/\$31.00 ©2016 IEEE.
- [3]. Prosanta Gope and Tzonelih Hwang, “BSN-Care: A Secure IoT-Based Modern Healthcare System Using Body Sensor Network” IEEE Sensors Journal, Vol. 16, no. 5, March 1, 2016,IEEE 1558-1748 © 2015 IEEE.
- [4]. Kaleem Ullah, MunamAli,“Effective Ways to Use Internet of Things in the Field of Medical and Smart Health Care”, 2015 International Conference on Identification, Information, and Knowledge in the Internet of Things, 978-1-4673-8753-8/16/\$31.00 ©2016 IEEE.
- [5]Mohanraj T, et al. (2017). “Patient Monitoring System Using LabVIEW”. International Journal of Engineering Science and Technology, Vol.24.

- [6] Lakmini P. Malasinghe et al., (2017) "Remote patient monitoring: a comprehensive study", Springer, DOI 10.1007/s12652-017-0598-x
- [7] Mohammad Shahidul Islam, et al., (2019) "Monitoring of the Human Body Signal through the Internet of Things (IoT) Based LoRa Wireless Network System".
- [8]. K. M. Monica, et al., (2020). "An Effective Patient Monitoring System using IOT International Journal of Recent Technology and Engineering (IJRTE) ISSN: 2277-3878, Volume-8 Issue-5, January 2020.
- [9] Ismail I., (2018) "Real-Time Healthcare Monitoring System Using Locally Made Device". Austin J Biosens & Bioelectron - Volume 4 Issue 1 - 2018 ISSN : 2473-0629
- [10]. Ms. Monali A Patil, (2016). "Wireless patient monitoring system & Its Performance Evaluation". International Journal of Robotics Research and Development (IJRRD), ISSN(P):2250-529;ISSN(E):2278-9421 Vol. 6, Issue 1, March 2016, 1-5
- [11]. N Deepak, et al., (2018). "Patient Health Monitoring using IoT". International Journal of Innovative Technology and Exploring Engineering (IJITEE) ISSN: 2278-3075, Volume-8 Issue-2S2 December, 2018 Vol.8, .
- [12]. Nagaraja B.G. and H.S. Jayanna, (2018) "Real-Time Healthcare Monitoring System Using Locally Made Device". Austin Journal of Biosensors & Bioelectronics Vol.4, No., pp.1-4.
- [13]. Mohanraj T, et al. (2017). "Patient Monitoring System Using LabVIEW". International Journal of Engineering Science and Technology, Vol.24,
- [14]. Rameswari.R, et al. (2018). "Smart Health Care Monitoring System Using Android Application". International Journal of Recent Technology and Engineering (IJRTE) Vol.7, No., pp..
- [15]. Harshitha Bhat Nishmitha Shetty, et al. (2018). "A Review on Health Monitoring System using IoT". International Journal of Engineering Research & Technology (IJERT), Vol.6, pp.
- [16]. C.Senthamilarasi, et al. (2018) "A SMART PATIENT HEALTH MONITORING SYSTEM USING IOT". International Journal of Soft Computing and Engineering (IJSCE). Vol.119, No.16, pp.59-70.
- [17]. U. Bhattacharjee, and K. Sarmah. (2012). "GMM-UBM Based Speaker Verification in Multilingual Environments". (IJCSI) International Journal of Computer Science, Vol.9, No.6, pp.373-380.
- [18]. Shivleela Patil, (2018). "Health Monitoring system using IoT", International Research Journal of Engineering and Technology (IRJET), Vol. 5 1 No. 4 1 pp.56-72 ARERSTEAI CRCLHE PAPERS.
- [19]. Prashant Patil, (2017). "Patient Health Monitoring System using IOT". International Research Journal of Engineering and Technology (IRJET), Vol.4, No.1, ISSN: 2395, pp.56-72.
- [20]. Swapnil R. Kurkute, et al. (2018). "Cattle Health Monitoring System". International Journal of Advanced Research in Computer and Communication Engineering Vol-7.