

## Single Stage Reconfigurable Inverter Cum Converter Grid Linked PV-Battery System

CH.SRINIVASULU REDDY<sup>1</sup>, N.MADHURI<sup>2</sup>

<sup>1</sup>Associate Professor, Dept of EEE, PBR Visvodaya Institute of Technology & Science, Kavali, AP, India.

<sup>2</sup>PG Scholar, Dept of EEE, Visvodaya Engineering College, Kavali, AP, India

---

**Abstract** - In this thesis a new converter called reconfigurable Solar Converter (RSC) for PV-battery application. Particularly for utility scale PV-battery application is proposed. The basic concept of the converter is to use a single power conversion system to perform different operation modes for solar PV systems with energy storage. The proposed solution requires minimal complexity and modifications to the conventional three-phase solar PV converters for PV-battery systems. The new converter is to use a single-stage three phase grid-tie solar PV converter to perform both dc/ac and dc/dc operations. This converter solution is appealing for PV-battery application, because it minimizes the number of conversion stages, thereby improving efficiency and reducing cost, weight, and its volume.

**Keywords**- Reconfigurable Converter, Energy Storage, Photovoltaic (PV), Solar.

---

### I. INTRODUCTION

Day-by-day the energy demand is increasing and thus the need for a renewable source that will not harm the environment are of prime importance. Yet majority of the energy requirements is satisfied by fossil fuels but by the use of photovoltaic systems could help in supplying the energy demands. Nowadays, renewable energy has been more and more attractive due to the severe environmental protection regulations and the shortage of conventional energy sources. Photovoltaic (PV) generation is the technique which uses photovoltaic cell to convert solar energy to electric energy [1]. Photovoltaic energy is assuming increasingly important as a renewable energy source because of its distinctive advantages, as simple configuration, easy allocation, free of pollution, low maintenance cost, etc, PV array is firstly connected to the common dc bus by a boost converter, where the battery is also connected by a bi-directional DC/DC converter, and then integrated into the ac utility grid by a common DC/AC inverter [2],[3]. Maximum power point tracking helps PV array to generate the maximum power to the grid, and the battery energy storage can be charged and discharge to balance the power between PV generation and utility grid [4]. There are different options for integrating energy storage into a Utility-scale solar PV system. Fig1 shows different scenarios for PV generation and load supply sequence. Every integration solution has its advantages and disadvantages. Different grouping solutions can be compared with regard to the number of power stages, efficiency, storage system flexibility, control complexity, etc.,[5].The main objective of the thesis is to design a single-stage inverter cum converter instead of multistage inverter cum converter[6],[7]. This proposed single-stage inverter cum converter (SSICC) performs different operations such as DC-AC & DC-DC in order to interconnect PV to Grid(dc to ac), PV to battery (dc to dc), battery to grid (dc to ac), and battery/PV to grid (dc to ac) for solar PV systems with energy storage[8],[9]. Section II introduces the proposed RSC circuit, different modes of operation, and system benefits. In Section III, control of the RSC is introduced

and necessary design considerations and modifications to the conventional three-phase PV converter are discussed. Section IV verifies the RSC with experimental results that demonstrate the attractive performance characteristics. Section V summarizes and concludes the paper.

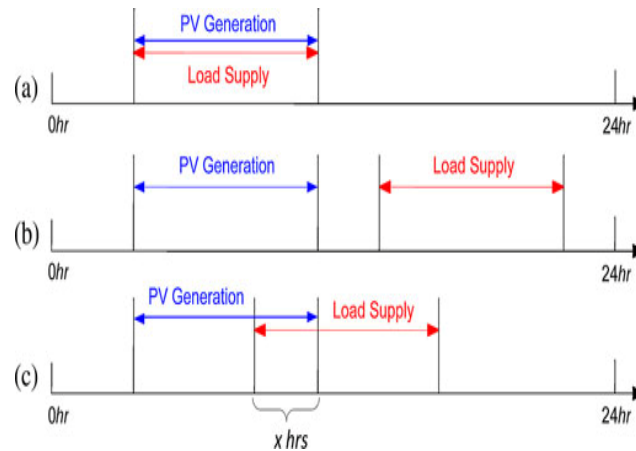
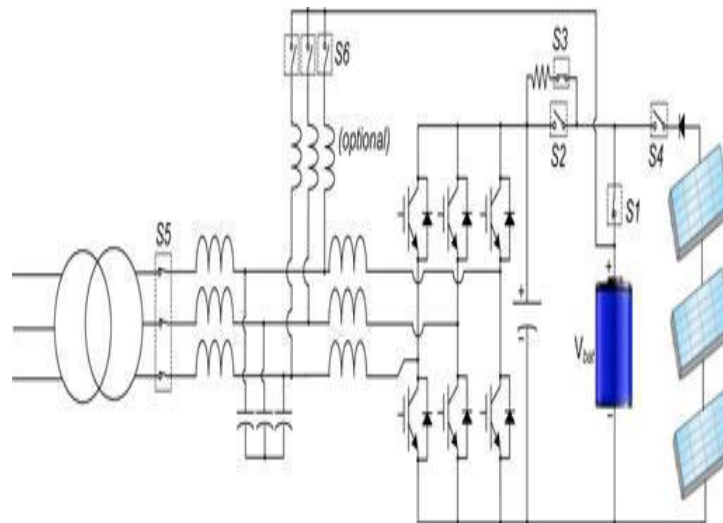

**Fig1. Different scenarios for PV Generation and load supply sequence.**

## II. RSC

### A. INTRODUCTION

The schematic of the proposed RSC is presented in Fig2. The RSC has some modifications to the conventional three phase PV inverter system. These modifications allow the RSC to include the charging function in the conventional three-phase PV inverter system. Assuming that the conventional utility-scale PV inverter system consists of a three-phase voltage source converter and its associated components, the RSC requires additional cables and mechanical switches, as shown in Fig. 2. Optional inductors are included if the ac filter inductance is not enough for the charging purpose



**Fig2. Schematic of the proposed RSC circuit.**

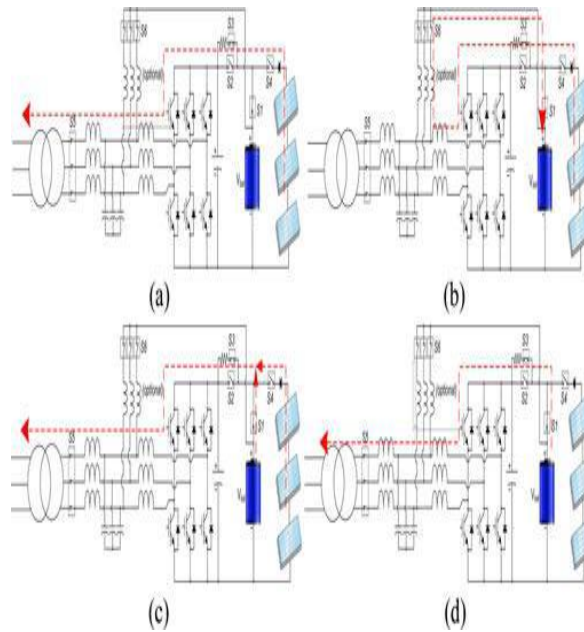

**Fig3. All operation modes of the RSC. (a) Mode 1—PV to grid. (b) Mode 2—PV to battery. (c) Mode 3—PV/battery to grid. (d) Mode 4—battery to grid.**

**B. Operation modes of RSC**

All possible operation modes for the RSC are presented in Fig. 3. In Mode 1, the PV is directly connected to the grid through a dc/ac operation of the converter with possibility of maximum power point tracking (MPPT) control and the S1 and S6 switches remain open. In Mode 2, the battery is charged with the PV panels through the dc/dc operation of the converter by closing the S6 switch and opening the S5 switch. In this mode, the MPPT function is performed; therefore, maximum power is generated from PV. There is another mode that both the PV and battery provide the power to the grid by closing the S1 switch. This operation is shown as Mode3. In this mode, the dc-link voltage that is the same as the PV voltage is enforced by the battery voltage; therefore, MPPT control is not possible. Mode4 represent an operation mode that the energy stored in the battery is delivered to the grid. There is another mode, Mode 5 that the battery is charged from the grid. This mode is not shown in Fig3.

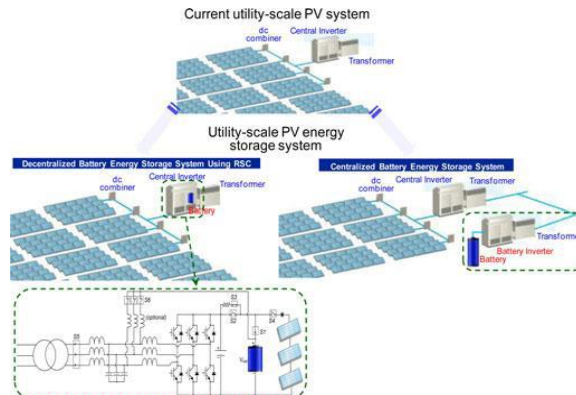

**Fig4. Utility-scale PV-energy storage systems with the RSC and the current state-of-the-art solution.**

### C. System Benefits of Solar PV Power Plant with the RSC Concept

The RSC concept provides significant benefits to system planning of utility-scale solar PV power plants. The current state-of-the-art technology is to integrate the energy storage into the ac side of the solar PV system. An example of commercial energy storage solutions is the distributed energy storage (DES) solution that is a complete package up to 4 MW, which is connected to the grids directly and, with its communication capabilities, can be utilized as a mean for peak shifting in solar PV power plants. The RSC concept allows not only the system owners to possess an expandable asset that helps them to plan and operate the power plant accordingly but also manufacturers to offer a cost-competitive decentralized PV energy storage solution with the RSC. Fig. 4 shows examples of the PV energy storage solutions with the RSC and the current state-of-the-art technology.

#### Single Stage Reconfigurable Inverter Cum Converter Grid Linked PV-Battery System

The technical and financial benefits that the RSC solution is able to provide are more apparent in larger solar PV power plants. Specifically, a large solar PV power plant using the RSCs can be controlled more effectively and its power can be dispatched more economically because of the flexibility of operation. Developing a detailed operation characteristic of a solar PV power plant with the RSC is beyond the scope of this paper. However, different system controls as shown in Fig. 5 can be proposed based on the requested power from the grid operator  $P_{req}$  and available generated power from the plant  $P_{gen}$ . These two values being results of an optimization problem (such as unit commitment methods) serve as variables to control the solar PV power plant accordingly. In other words, in response to the request of the grid operator, different system control schemes can be realized with the RSC-based solar PV power plant as follows:

1. System control 1 for  $P_{gen} > P_{req}$ ;
2. System control 2 for  $P_{gen} < P_{req}$ ;
3. System control 3 for  $P_{gen} = P_{req}$ ;
4. System control 4 for charging from the grid (Operation Mode 5).

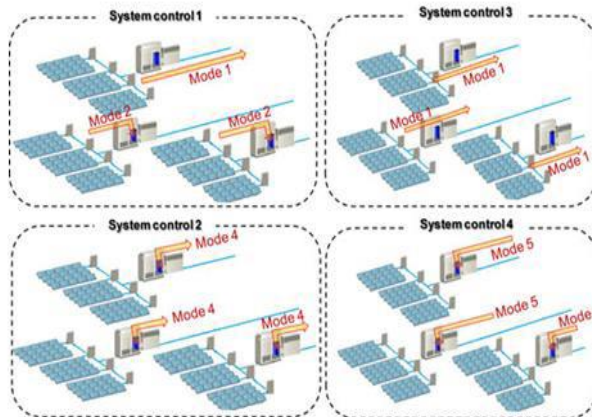

**Fig5. Example of different system operation modes of a RSC-based solar PV power plant.**

### III.RSC CONTROL

#### A. Control of the RSC in the DC/AC Operation Modes (Modes 1, 3, 4, and 5)

The dc/ac operation of the RSC is utilized for delivering power from PV to grid, battery to grid, PV and battery to grid, and grid to battery. The RSC performs the MPPT algorithm to deliver maximum power from the PV to the grid. Like the conventional PV inverter control, the RSC control is implemented in the synchronous reference frame. The synchronous reference frame proportional-integral current control is employed. In a reference frame rotating synchronously with the fundamental excitation, the fundamental excitation signals are transformed into dc signals. As a result, the current regulator forming the innermost loop of the control system is able to regulate ac currents over a wide frequency range with high bandwidth and zero steady-state error. For the pulse width modulation (PWM) scheme, the conventional space vector PWM scheme is utilized. Fig. 6 presents the overall control block diagram of the RSC in the dc/ac operation. For the dc/ac operation with the battery, the RSC control should be coordinated with the battery management system (BMS), which is not shown in Fig. 6.

#### B. Control of the RSC in the DC/DC Operation Mode (Mode 2)

The dc/dc operation of the RSC is also utilized for delivering the maximum power from the PV to the battery. The RSC in the dc/dc operation is a boost converter that controls the current flowing into the battery. In this research, Li-ion battery has been selected for the PV-battery systems. Li-ion batteries require a constant current, constant voltage type of charging algorithm. In other words, a Li-ion battery should be charged at a set current level until it reaches its final voltage. At the final voltage, the charging process should switch over to the constant voltage mode, and provide the current necessary to hold the battery at this final voltage. Thus, the dc/dc converter performing charging process must be capable of providing stable control for maintaining either current or voltage at a constant value, depending on the state of the battery. Typically, a few percent capacity losses happen by not performing constant voltage charging. However, it is not uncommon only to use constant current charging to simplify the charging control and process. The latter has been used to charge the battery. Therefore, from the control point of view, it is just sufficient to control only the inductor current. Like the dc/ac operation, the RSC performs the MPPT algorithm to deliver maximum power from the PV to the battery in the dc/dc operation. Fig. 7 shows the overall control block diagram of the RSC in the dc/dc operation. In this mode, the RSC control should be coordinated with the BMS, which is not shown in Fig. 7.

#### C. Design Considerations and Modifications to the Conventional Three-Phase PV Converter

One of the most important requirements of the project is that a new power conversion solution for PV-battery systems must have minimal complexity and modifications to the conventional three-phase solar PV converter system. Therefore, it is necessary to investigate how a three-phase dc/ac converter operates as a dc/dc converter and what modifications should be made. It is common to use a *LCL* filter for a high-power three-phase PV converter and the RSC in the dc/dc operation is expected to use the inductors already available in the *LCL* filter. There are basically two types of inductors, coupled three-phase inductor and three single-phase inductors that can be utilized in the

RSC circuit. Using all three phases of the coupled three-phase inductor in the dc/dc operation causes a significant drop in the inductance value due to inductor core saturation.

Table I presents an example of inductance value of a coupled three-phase inductor for the dc/dc operation, which shows significant drop in the inductance value. The reduction in inductance value requires inserting additional inductors for the dc/dc operation which has been marked as “optional” in Fig. 2. To avoid extra inductors, only one phase can perform the dc/dc operation. However, when only one phase, for instance phase B, is utilized for the dc/dc operation with only either upper or lower three insulated-gate bipolar transistors (IGBTs) are turned OFF as complementary switching, the circulating current occurs in phases A and C through filter capacitors, the coupled inductor, and switches, resulting in significantly high current ripple in phase B current.

To prevent the circulating current in the dc/dc operation, the following two solutions are proposed;

1. All unused upper and lower IGBTs must be turned OFF;
2. The coupled inductor is replaced by three single-phase inductors.

While the first solution with a coupled inductor is straight- forward, using three single-phase inductors makes it possible to use all three phase legs for the dc/dc operation. There are two methods to utilize all three phase legs for the dc/dc operation:

1. Synchronous operation
2. Interleaving operation.

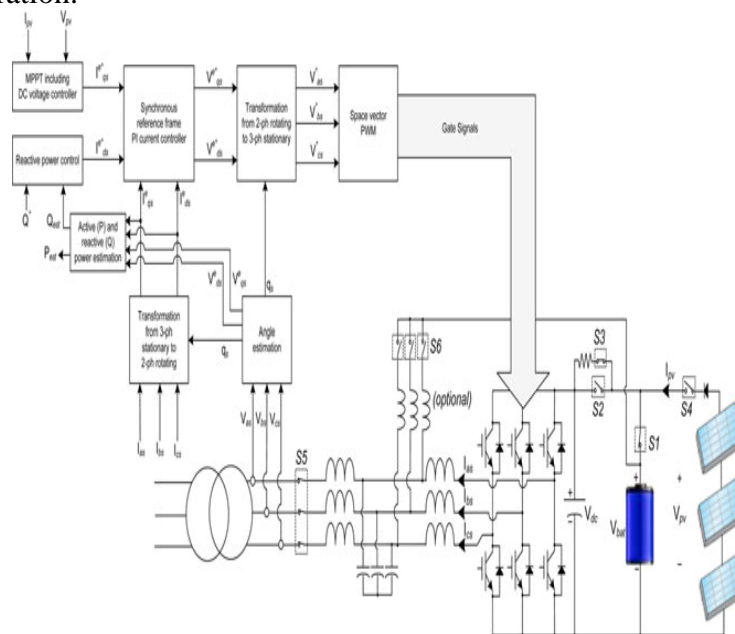

**Fig.6. Overall control block diagram of the RSC in the dc/ac operation.**

In the first solution, all three phase legs can operate synchronously with their own current control. In this case, the battery can be charged with a higher current compared to the case with one-phase dc/dc operation. This leads to a faster charging time due to higher charging current capability. However, each phase operates with higher current ripples. Higher ripple current flowing into the battery and capacitor can have negative effects on the lifetime of the battery and capacitors. To overcome the aforementioned problem associated with the synchronous operation, phases B and C can be shifted by applying a phase offset. For the interleaving operation using three phase legs,

phases B and C are shifted by 120° and 240°, respectively. The inductor current control in interleaving operation

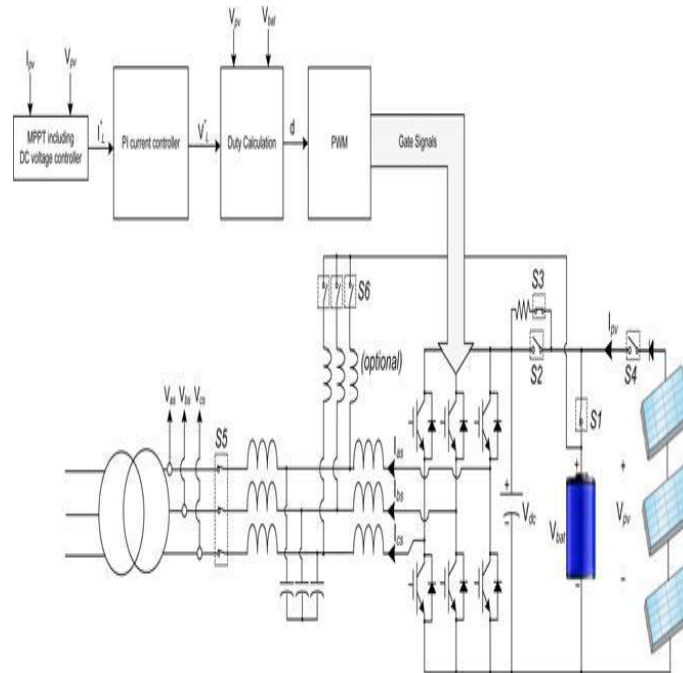

**Fig7. Overall control block diagram of the RSC in the dc/dc operation**

**TABLE I: Lithium-Ion K2 Battery Parameters**

|                                    |                 |                    |
|------------------------------------|-----------------|--------------------|
| <b>Battery capacity</b>            | <b>Kwhr/Ahr</b> | <b>5.9/51.2</b>    |
| <b>Battery nominal voltage</b>     | <b>V</b>        | <b>115.2</b>       |
| <b>Min battery voltage</b>         | <b>V</b>        | <b>90</b>          |
| <b>Max discharge current</b>       | <b>A</b>        | <b>52</b>          |
| <b>Max pulse discharge current</b> | <b>A</b>        | <b>150(&lt;2S)</b> |
| <b>Max charging voltage</b>        | <b>V</b>        | <b>132</b>         |
| <b>Max charging current</b>        | <b>A</b>        | <b>10</b>          |

Requires a different inductor current sampling scheme. In general, for digital control of a dc/dc converter, the inductor current is sampled at either the beginning or centre point of PWM to capture

the average current that is free from switching noises. For two phase interleaving that two phases are  $180^\circ$  apart, there is no need to modify the sampling scheme, since the average inductor currents for both phases can be obtained with the conventional sampling scheme. For three-phase interleaving, a modified sampling scheme is required to measure the average currents for all three phases. Therefore, the sampling points for phases B and C must be shifted by  $120^\circ$  and  $240^\circ$ , respectively which may imply that computation required inductor current control for each phase should be done asynchronously. Using the interleaving operation reduces the ripples on the charging current flowing into the battery.

#### IV. SIMULATION RESULTS

This section presents simulation output results for Single Stage Reconfigurable Inverter Cum Converter Grid Linked PV Battery System

#### V. CONCLUSION

This paper introduced a new converter called RSC for PV-battery application, particularly utility-scale PV-battery application.

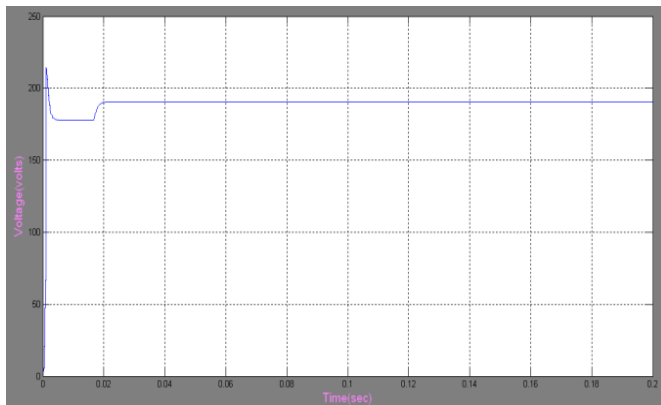

(a) PV output voltage

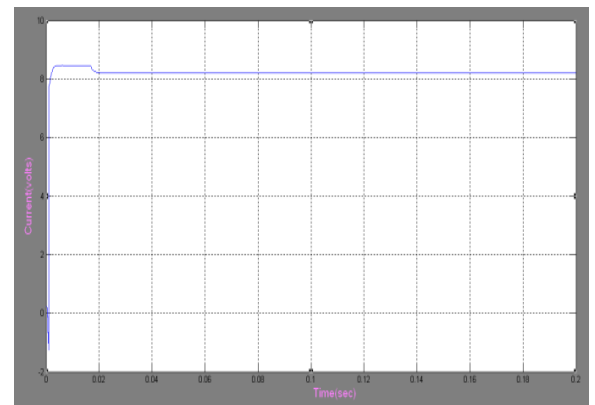

(b) PV output current

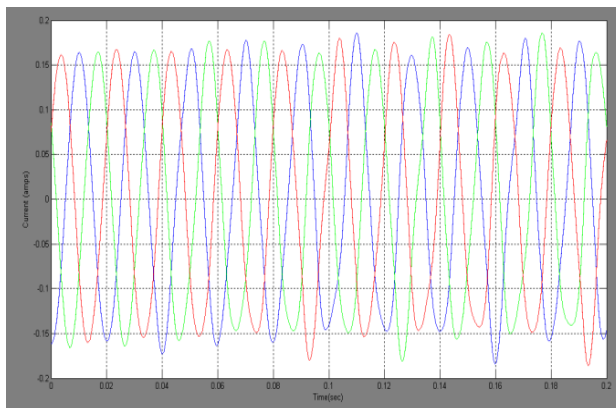

(c) Three phase current

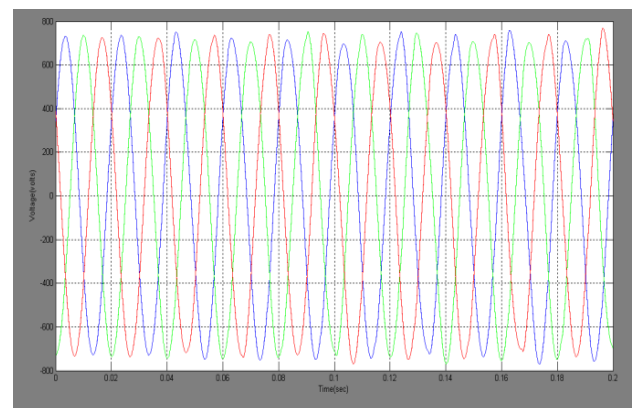

(d) Three phase voltage



**Fig8. Simulation results of (a) PV output voltage, (b) PV output current, (c) Three phase current, (d)Three phase voltage.**

The figure 8 shows the simulation results of SSIC where the pv output voltage is 191 volts, pv current 8 amps, three phase voltage and current are 700 volts and 0.15 amps respectively, it is observed that the three phase voltage and current are in sinusoidal form. The basic concept of the RSC is to use a single power conversion system to perform different operation modes such as PV to grid (dc to ac), PV to battery (dc to dc), battery to grid (dc to ac), and battery/PV to grid (dc to ac) for solar PV systems with energy storage. The proposed solution requires minimal complexity and modifications to the conventional three-phase solar PV converters for PV-battery systems. Therefore, the solution is very attractive for PV-battery application, because it minimizes the number of conversion stages, thereby improving efficiency and reducing cost, weight, and volume. Test results have been presented to verify the concept of the RSC and to demonstrate the attractive performance characteristics of the RSC. These results confirm that the RSC is an optimal solution for PV-battery power conversion systems. Although this paper focuses on three-phase application, the main concept can be applied to single-phase application. The proposed solution is also capable of providing potential benefits to other intermittent energy sources including wind energy.

## REFERENCES

- [1] U.S. Department of Energy, "Solar energy grid integration systems-energy storage (SEGIS-ES)," May 2008.
- [2] H. Ertl, J. W. Kolar, and F. Zach, "A novel multicell dc-ac converter for applications in renewable energy systems," *IEEE Trans. Ind. Electron.*, vol. 49, no. 5, pp. 1048–1057, Oct. 2002.
- [3] C. Zhao, S. D. Round, and J. W. Kolar, "An isolated three-port bidirectional dc/dc converter with decoupled power flow management," *IEEE Trans. Power Electron.*, vol. 23, no. 5, pp. 2443–2453, Sep. 2008.
- [4] C. Ho, H. Breuninger, S. Pettersson, G. Escobar, L. Serpa, and A. Coccia, "Practical design and implementation procedure of an interleaved boost converter using SiC diodes for PV applications," *IEEE Trans. Power Electron.*, vol. 27, no. 6, pp. 2835–2845, Jun. 2012.
- [5] M. Bragard, N. Soltau, R. W. De Doncker, and A. Schmiegel, "Design and implementation of a 5 kW PV system with Li-ion battery and additional dc/dc convert-er," in *Proc. IEEE Energy Convers. Congr. Expo.*, 2010, pp. 2944–2949.
- [6] F. Ding, P. Li, B. Huang, F. Gao, C. Ding, and C. Wang, "Modeling and Simulation of grid connected hybrid PV/battery distributed generation system," in *Proc. China Int. Conf. Electr. Distrib.*, 2010, pp. 1–10.
- [7] S. Jain and V. Agarwal, "An integrated hybrid power supply for distributed generation application fed by non conventional energy sources," *IEEE Trans. Energy Convers.*, vol. 23, no. 2, pp. 622–631, Jun. 2008.
- [8] Z. Wang, X. Li, and G. Li, "Energy Storage control for the PV generation system in micro-grid," in *Proc. 5th Int. Conf. Critical Infrastructure*, Sep. 2010, pp. 1–5.
- [9] N. K. Bhattacharya, S. R. B. Chaudhari, and D. Mukherjee, "PV Embedded grid connected substation for enhancement of energy security," in *Proc. IEEE Photovoltaic Spec. Conf.*, Jun. 2009, pp. 002370–002374.
- [10] S. A. Zabalwi, G. Mandic, and A. Nasiri, "Utilizing energy storage with PV for residential and commercial use," in *Proc. IEEE Ind. Electron. Conf.*, Nov. 2008, pp. 1045–1050.

## AUTHOR'S PROFILE:

### CH. SRINIVASULU REDDY

He is currently working as Associate Professor, Dept. of EEE, PBR Visvodaya Institute of Technology and Science, Kavali. He is a HOD of EEE department

**N. MADHURI** now doing M.Tech from Visvodaya Engineering College, Kavali.